

ENGINE

Model	ISM N844LTA-DI-F-45/E4
Type	Diesel 4-stroke, Turbo, D.I.
Cylinders	4
Bore/Stroke	3.31 x 3.94 in (84 x 100 mm)
Displacement	135.2 in ³ (2.2 L)
Fuel injection	Direct, high pressure common rail – HPCR
Fuel	#2 Diesel
Fuel filter:	
Pre-filter	Beta (30) = 200/spin on
Main filter	Beta (4) = 20/spin on
Air intake	Turbocharged and intercooled w/ external EGR
Exhaust aftertreatment	Diesel oxidation catalyst – DOC
Cooling	Liquid
Engine speeds	RPM
High idle – no load	2825 +/- 25
Rated – full load	2800
Low idle	1200 +/- 50
Horsepower @ 2800 RPM – SAE J1349:	
Gross	60 hp (44.7 kW)
Net	57 hp (42.4 kW)
Peak torque @ 1800 RPM	135 lb-ft (183 N-m)
Radiator:	
Core type	All aluminum
Core size area	2.05 ft ² (0.191 m ²)
Rows of tubes x columns	31 x 4
Cap pressure	16 +/- 2 psi (1.10 +/- 0.14 bar)
Fan:	
Diameter	17.7 in (450 mm)
Ratio	0.89:1
Water pump:	
Style	Centrifugal
Flow	14.7 gpm (55.5 L/min)
Engine lubrication pump	Pressure feed w/ Trichoid pump
Pump operating angle ratings:	
Side to side	35°
Bucket up	35°
Bucket down	35°

POWERTRAIN

Drive pump controls	Direct mechanical
Pump to engine ratio	1:1
Displacement	2.14 in ³ (35 cc)
Flow @ rated engine RPM:	
@ 97% efficiency	25.1 gpm (95 L/min)
Charge pressure	360 psi (24.5 bar)
System relief pressure	5,000 psi (345 bar)
Drive pump controls	Electro-hydraulic
Pump to engine ratio	1:1
Displacement	2.14 in ³ (35 cc)
Flow @ rated engine RPM:	
@ 97% efficiency	25.1 gpm (95 L/min)
Charge pressure	362 psi (24.5 bar)
System relief pressure	5,220 psi (360 bar)

POWERTRAIN (cont.)

Drive motors:	
Max. displacement	19.8 in ³ (325 cc)
Displacement – optional:	
High speed	12.2 in ³ (200 cc)
Motor RPM @ high idle and 97% efficiency:	
Standard 1-speed	313
Optional 2-speed	443
Motor torque @ max. displacement and relief pressure, calculated @ 5,000 psi (345 bar):	1,315 lb-ft (1783 N-m)
Travel speed:	
Low range	7.4 mph (11.9 kph)
High range – optional	10.8 mph (17.4 kph)
Final drive	Single-reduction chain drive
Drive chain:	
Size	ASA #80
Tensile strength	21,000 lb (93.4 kN)
Axles:	
Torque @ max. displacement and relief pressure	4,381 lb-ft (5940 N-m)
Diameter	2.0 in (50.8 mm)
Length	15.1 in (384 mm)
Parking brake:	
Type	Spring-applied, hydraulic release multiple disc.
Engagement	Depress on/off brake button on handle or instrument panel, raise seat bar, get off seat, or stop engine.

ELECTRICAL

Alternator	120 amp
Starter	2.68 hp (2.0 kW)
Battery	12-volt low-maintenance 925 cold-cranking amps @ 0° F (-18° C)

OPERATOR ENVIRONMENT

ROPS/FOPS level 1 canopy w/ side screens; Tilt ROPS/FOPS; Rear window w/ emergency escape; Instrument panel w/ hour meter, tachometer, fuel level, hydraulic oil temperature, engine coolant temperature, diagnostic features, and security lockout; Non-suspension vinyl seat; 2 in (51 mm) retractable lap seat belt; Hand and foot throttles; Alarm package – back-up and horn; Headliner; Dome light; Top window; Cup holder; 12-volt power plug socket; Foot rest; Storage tray; Low effort ergonomic hand controls; Padded seat bar w/ integral armrests; Loader control lockout system; Electric parking brake control; Floor cleanout panel; Proportional auxiliary hydraulic control – on joystick.

Indicators:	Digital hourmeter; Fuel level LCD bar graph w/ alarm.
Warning lights w/ alarms:	Engine coolant temperature; Engine oil pressure; Engine malfunction; Hydraulic charge pressure; Hydraulic filter restriction; Hydraulic oil temperature.

OPERATOR ENVIRONMENT (cont.)

Warning alarms:	Battery voltage – plus display
Indicator light:	Engine preheat; Parking brake; Seat bar reminder.

OPERATING WEIGHT

Operating weight	6,570 lb (2980 kg)
Shipping weight	6,270 lb (2840 kg)
Add-on weights:	
Side cab glass	47 lb (21.3 kg)
Polycarbonate cab door	74 lb (33.6 kg)
Glass cab door w/ wiper	134 lb (60.8 kg)
Suspension seat	22 lb (10 kg)
Additional counterweight	140 lb (63.8 kg)

HYDRAULICS

Implement pump type	Gear
Displacement:	
Standard aux.	1.7 in ³ (27.8 cc)
High flow aux.	0.84 in ³ (13.8 cc)
Standard flow @ rated engine RPM: @ 100% efficiency	20.6 gpm (78 L/min)
Optional high flow @ rated engine RPM: @ 100% efficiency	30.7 gpm (116.2 L/min)
Loader control valve:	
Type	3 spool/open center/series - series
Relief pressure	3,050 psi (210 bar)
Port relief pressures:	
Loader raise	3,263 psi (225 bar)
Bucket curl	3,770 psi (260 bar)
Bucket dump	1,160 psi (80 bar)
Hydraulic lines:	
Tubing	37° JIC Flare
Loop hoses	SAE 100 R19

Hydraulic oil cooler:	
Number of fins	10 per inch (3.94 per cm)
Number of tube rows x columns	9 x 1
Area	130.7 in ² (843.2 cm ²)
Hydraulic filter	Beta (4) = 75/spin on
Lift cylinders:	
Bore diameter	2.50 in (63.5 mm)
Rod diameter	1.75 in (44.45 mm)
Stroke	26.81 in (681 mm)
Closed length	38.66 in (982 mm)
Bucket cylinders:	
Bore diameter	2.50 in (63.5 mm)
Rod diameter	1.38 in (34.9 mm)
Stroke	16.14 in (410 mm)
Closed length	24.02 in (610 mm)

SERVICE CAPACITY

Fuel tank	19.5 gal (73.8 L)
Engine oil w/ filter	7.5 qt (7.1 L)
Hydraulic system:	
Reservoir	4.3 gal (16.3 L)
Total	8.5 gal (32.2 L)
Chain tanks – per side	1.95 gal (7.4 L)

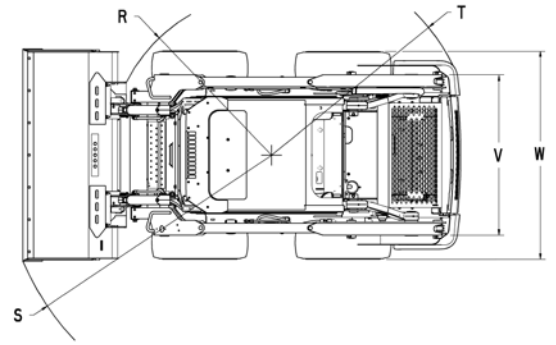
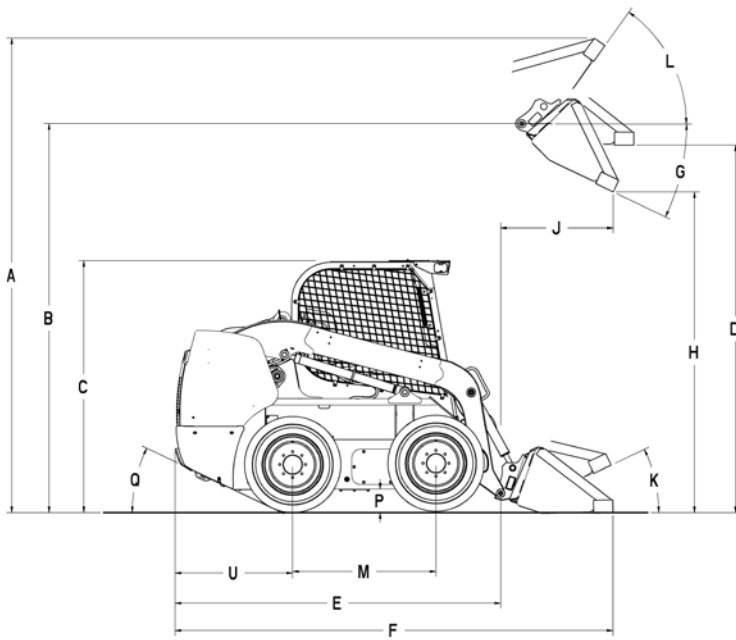

Line drawings are for illustrative purpose only and may not be exact representation of unit.

PERFORMANCE SPECS

Rated operating capacity – ROC:	
50% of tipping load	1,850 lb (840 kg)
with additional counterweight	1,950 lb (885 kg)
Tipping load	3,700 lb (1678 kg)
Breakout forces @ 3,150 psi (217 bar):	
Bucket cylinders	5,550 lb (24.7 kN)
Lift cylinders	3,450 lb (15.3 kN)
Cycle times:	
Raise	3.5 sec
Lower	2.7 sec
Dump	2.1 sec
Roll back	1.5 sec

DIMENSIONS

A. Overall operating height:	
with foundry/excavating bucket	150.4 in (3.82 m)
with low profile bucket	154.6 in (3.93 m)
with low profile extended bucket	159.6 in (4.06 m)
Height to:	
B. Bucket hinge pin	120 in (3.05 m)
C. Top of ROPS	77.7 in (1.97 m)
D. Bottom of level bucket, fully raised	113.3 in (2.88 m)
Overall length:	
E. without attachment with coupler	105.7 in (2.69 m)
F. with foundry/excavating bucket on ground	131.7 in (3.35 m)
with low profile bucket	135.8 in (3.45 m)
with low profile extended bucket	140.9 in (3.58 m)
G. Maximum dump angle	51.9°
H. Dump height:	
with foundry/excavating bucket	93.7 in (2.38 m) @ 45°
with low profile bucket	90.7 in (2.31 m) @ 45°
J. Dump reach at maximum height with low profile bucket	33.7 in (0.86 m) @ 45°
Maximum attachment rollback:	
K. Bucket on ground	35.0°
L. Bucket at full height	87.6°
M. Wheelbase	44.4 in (1.13 m)
P. Ground clearance – bottom of belly pan	7.0 in (0.18 m)
Q. Angle of departure	23°
Clearance circle:	
R. without bucket	50.7 in (1.29 m)
S. with 66 in (1.68 m) foundry/excavating bucket in carry position	79.6 in (2.02 m)
with 66 in (1.68 m) low profile bucket on ground	83.9 in (2.13 m)
with 66 in (1.68 m) extended low profile on ground	88.6 in (2.25 m)
T. Clearance circle rear	62.9 in (1.60 m)
U. Rear axle to bumper	36.4 in (0.92 m)
V. Tread gage with spec tires	53.9 in (1.37 m)
W. Over the tire width with spec tires	64 in (1.63 m)

TIRE SELECTION

	Size	Ply Rating	Tread Depth	Tire Width	Tread Gage	Over Tires Width	Each Tire Weight
Heavy-Duty	10 L x 16.5	—	—	—	53.9 in (1.37 m)	64 in (1.63 m)	87 lb (39.5 kg)
Premium	10 L x 16.5	—	—	—	53.9 in (1.37 m)	64 in (1.63 m)	96 lb (44.0 kg)
Premium-Lined	10 L x 16.5	—	—	—	53.9 in (1.37 m)	64 in (1.63 m)	63 lb (28.5 kg)
Severe Duty	10 L x 16.5	—	—	—	53.9 in (1.37 m)	64 in (1.63 m)	115 lb (52.5 kg)
Non-Pneumatic	10 L x 16.5	—	—	—	53.9 in (1.37 m)	64 in (1.63 m)	229 lb (104 kg)
Heavy-Duty	12 L x 16.5	—	—	—	—	70 in (1.78 m)	110 lb (50 kg)
Premium	12 L x 16.5	—	—	—	—	70 in (1.78 m)	120 lb (54.5 kg)
Premium Lined	12 L x 16.5	—	—	—	—	70 in (1.78 m)	120 lb (54.5 kg)

OPTIONAL BUCKETS

Type	Width	Weight	Heaped Capacity
Dirt & Foundry	66 in (1.68 m)	385 lb (175 kg)	14.8 ft ³ (0.42 m ³)
	72 in (1.83 m)	420 lb (190 kg)	16.2 ft ³ (0.46 m ³)
	78 in (1.98 m)	440 lb (200 kg)	17.7 ft ³ (0.50 m ³)
Low Profile	66 in (1.68 m)	440 lb (200 kg)	13.4 ft ³ (0.38 m ³)
	72 in (1.83 m)	480 lb (218 kg)	14.8 ft ³ (0.42 m ³)
Low Profile Extended	66 in (1.68 m)	470 lb (214 kg)	15.9 ft ³ (0.45 m ³)
	72 in (1.83 m)	510 lb (232 kg)	17.7 ft ³ (0.50 m ³)
	78 in (1.98 m)	540 lb (245 kg)	19.1 ft ³ (0.54 m ³)
	84 in (2.13 m)	575 lb (262 kg)	20.5 ft ³ (0.58 m ³)
Light Material	72 in (1.83 m)	475 lb (216 kg)	23.3 ft ³ (0.66 m ³)
	84 in (2.13 m)	540 lb (245 kg)	27.5 ft ³ (0.78 m ³)
Manure & Slurry	72 in (1.83 m)	480 lb (218 kg)	19.1 ft ³ (0.54 m ³)
	84 in (2.13 m)	545 lb (248 kg)	22.6 ft ³ (0.64 m ³)
Heavy-Duty	66 in (1.68 m)	450 lb (205 kg)	13.1 ft ³ (0.37 m ³)
	72 in (1.83 m)	510 lb (230 kg)	14.1 ft ³ (0.40 m ³)
	78 in (1.98 m)	530 lb (240 kg)	15.5 ft ³ (0.44 m ³)
	84 in (2.13 m)	550 lb (250 kg)	17.0 ft ³ (0.48 m ³)
Heavy-Duty with spillguard	66 in (1.68 m)	520 lb (235 kg)	16.6 ft ³ (0.47 m ³)
	72 in (1.83 m)	585 lb (265 kg)	18.4 ft ³ (0.52 m ³)
	78 in (1.98 m)	605 lb (275 kg)	19.8 ft ³ (0.56 m ³)
	84 in (2.13 m)	640 lb (290 kg)	21.5 ft ³ (0.61 m ³)

STANDARD EQUIPMENT

OPERATOR ENVIRONMENT

See page 1

ENGINE

ISM N844LTA-DI-F-45 diesel
Over & under radiator and oil cooler
Glow plugs
Integral engine oil cooling
Fuel filter with water trap
Dual element air cleaner
120 amp alternator
925 CCA 12-volt battery
Master electrical disconnect

POWERTRAIN

1-speed hydrostatic four wheel drive
Servo-assist mechanically-controlled pumps
ASA #80HS drive chain
SAHR disc parking brake

HYDRAULICS

Auxiliary hydraulics:
@ 3,050 psi (210 bar) – 20.6 gpm (78 L/min)
Auxiliary hydraulic disconnects, ISO flat-face –
connect-under-pressure with case drain
Hydraulic circuit pedal lock
Loader arm-mounted ISO flat face connectors
Auxiliary function lockout override
Loader function lockout system
Loader lift lockout override
3-spool loader control valve
Heavy-duty oil cooler
Loader arm float position

LOADER

Vertical loader arm design
Mechanical attachment coupler
Loader lift arm support strut

OTHER

Machine protection auto shutdown
Mounting points for add-on counterweights
Halogen lights:
2 front
2 side
2 rear flood
Rear tail lights
Lockable service access hood
Single-point daily servicing
Pre-wired for rotating beacon
Remote oil drain
Remote oil and fuel filters

OPTIONAL EQUIPMENT

OPERATOR ENVIRONMENT

Electro-hydraulic controls:
For drive/steering, loader functions
Switchable between H and ISO patterns
Adjustable sensitivity of controls
Vinyl mechanical suspension seat
Deluxe cloth, air suspension seat,
with heater and lumbar support
Interior mirror
Enclosed cab including glass door with
wiper and washer, sliding side windows,
heater, shoulder belt, radio with speakers,
keyless start
3 inch (76.2 mm) retractable seat belt
Heater and air conditioner
Open cab interior trim package
Demolition cab door with polycarbonate
FOPS level 2

POWERTRAIN

2-speed hydrostatic four wheel drive

ENGINE

Coolant block heater

HYDRAULICS

High-flow auxiliary hydraulics – combined:
@ 3,050 psi (210 bar) – 30.7 gpm (116.2 L/min)
Second auxiliary hydraulics

LOADER

Auxiliary front electric control
Ride control
Hydraulic attachment coupler
Hydraulic one-way self-leveling

OTHER

Add-on counterweights
Road lights
Rotating beacon
Four-corner LED strobe
Lift points – four-point or single-point
Language decals
Factory-installed tires – see page 3
Buckets – see page 3
Bolt-on bucket cutting edges
Bolt-on heavy-duty bucket spillguard
Bolt-on heavy-duty bucket teeth – field kit
42 in (1.07 m) and 48 in (1.22 m) pallet fork
Rear door guard insert
Special paint
Steel tire tracks



NOTE: All specifications are stated in accordance with SAE Standards or Recommended Practices, where applicable.

NOTE: All engines meet current EPA emissions requirements.

IMPORTANT: Case Construction Equipment Inc. reserves the right to change these specifications without notice and without incurring any obligation relating to such change. Case Construction Equipment Inc. does not warrant the safety or reliability of attachments from other manufacturers.

Case is a registered trademark of CNH America LLC. Any trademarks referred to herein, in association with goods and/or services of companies other than CNH America LLC, are the property of those respective companies.

Form No. CCE201302SV185
Replaces form no. CCE201105SV185

Printed in U.S.A.
SV185 • Page 4 of 4



www.casece.com

© 2013 CNH America LLC
All Rights Reserved



All Case construction equipment is biodiesel ready.